

THIS DRAWING HAS BEEN GENERATED BY A CAD SYSTEM. CHANGES SHALL ONLY BE INCORPORATED AS DIRECTED BY THE DESIGN ACTIVITY. DO NOT REVISE MANUALLY.

REVISIONS			
REV.	DESCRIPTION	ECO	DATE
B	ADD ISOMETRIC VIEW	18-010	11/14/18
			APPROVED
			P.T

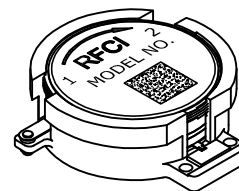
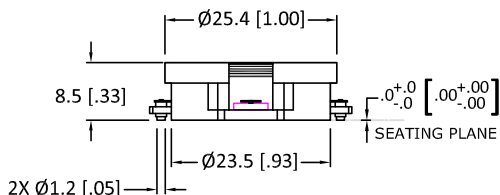
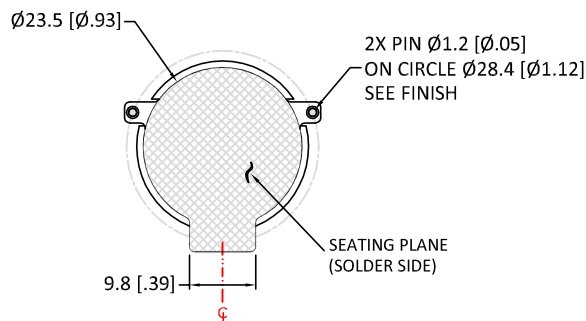
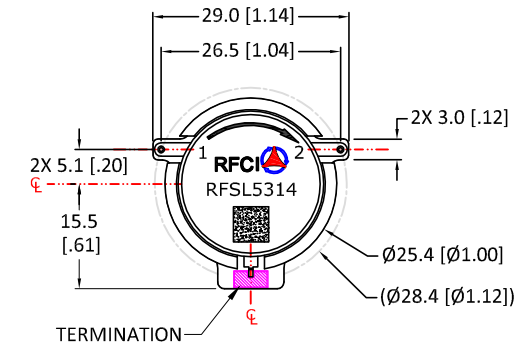

**Terminal:**  
 Port (1): Input  
 Port (2): Output

**Finish:**  
 1. Housing: Silver plated  
 2. Pin: Gold plated  
 3. Coplanarity specification: 0.10 [.004] MAX.

**Specifications**

Parameter	Minimum	Typical	Maximum
Frequency Range (MHz)	1420		1520
Insertion Loss: 1 to 2 (dB)		< .25	.30
Isolation: 2 to 1(dB)	20	> 23	
Return Loss: 1, 2 (dB)	20	> 23	

**Notes:**

1. Typical Values Represent Performance @ +23 °C.
2. Isolator Flange held to +85°C; 30 Min. maximum Duration.

**Power & Temperature Ratings**

Parameter	Maximum
Forward PWR Peak/AVG	500/100 Watts
Reverse Power CW	20 Watts
Termination Rating (See Note 2)	20 Watts
Operating Temperature	-40 to +85° C
Storage Temperature	-50 to +125° C

Permanent damage to the Device or reduce reliability if exceeding any of the limits.  
 Port (1) and (2): DC connected and floating with the 50 ohm resistance of the internal load as the only ground connection.

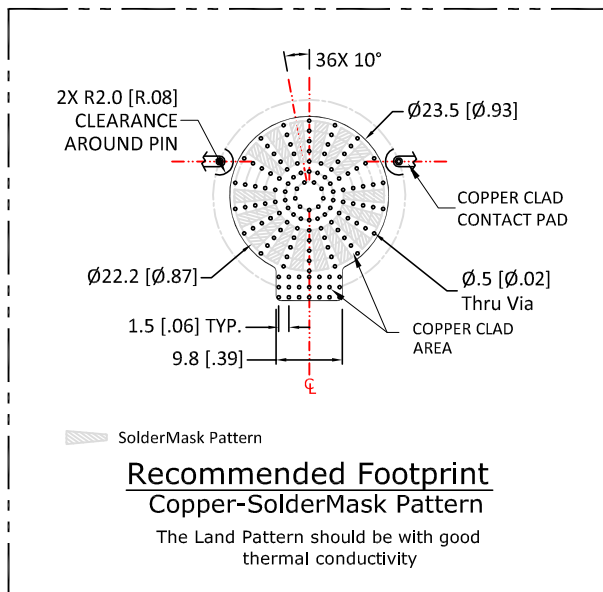

**CW SMD ISOLATOR MODEL: RFSL5314**

<p>UNLESS OTHERWISE SPECIFIED                  ALL DIMENSIONS ARE IN MILLIMETERS (INCHES):</p> <p>TOLERANCES ARE:                  1 PLACE DECIMAL ±.2 [±.01] ANGULAR: ±1.0°                  2 PLACE DECIMAL ±.10 [±.004] SURFACE ROUGHNESS 16/</p> <p>REMOVE ALL BURRS AND BREAK SHARP EDGES.                  SURFACE TEXTURE TO BE IN ACCORDANCE WITH LATEST ANSI B46.1                  DIMENSIONING &amp; TOLERANCING IN ACCORDANCE WITH LATEST ANSI Y14.5</p> <p>PROPRIETARY NOTE: "THE INFORMATION CONTAINED ON THIS DOCUMENT IS CONSIDERED TO BE CONFIDENTIAL MATERIAL PROPRIETARY TO RF CIRCULATOR ISOLATOR Inc. (RFCI) AND IS PROVIDED SOLELY FOR INFORMATION PURPOSES.                  THIS INFORMATION SHALL NOT BE USED BY ANYONE OTHER THAN RFCI TO DESIGN OR CONSTRUCT ANY OF THE ITEMS DEPICTED, NOR SHALL IT BE DISCLOSED, DUPLICATED, OR COPIED FOR ANY PURPOSE, NOR MADE AVAILABLE TO ANY THIRD PARTY WITHOUT THE PRIOR WRITTEN CONSENT OF A RFCI OFFICIAL."</p>	<p>THIRD ANGLE PROJECTION</p>	<p><b>RFCI</b></p>		
	<p>APPROVALS</p> <p>DATE</p>		<p><b>OUTLINE/SPECS</b></p>	
<p>DRAWN BY:</p> <p>CHECKED BY:</p> <p>DESIGN BY:</p> <p>ENGINEER BY:</p> <p>MFG. ENGR.</p> <p>Q.A.</p> <p>PROG. MGMT/MKT</p>	<p>SIZE</p> <p>A</p>	<p>CAGE NO.</p>		<p>DWG NO.</p> <p>SL5314-OS</p>
<p>DO NOT SCALE DRAWING</p>	<p>SCALE: FULL</p>	<p>SHEET 1 OF 1</p>		